



In line pressure compensated single-acting flow control valves

FT 277/5

Compensated single-acting flow control valves available from 1/4" to 3/4" BSPP, max.working pressure 320 Bar, adjustable oil flow rate from 5 to 75 Lt./min. (depending on the size) - Precision in compensation +/- 1% max

Single-acting control

Pressure compensated In line or panel mounting

Carbon steel

Connections: F - F Female - Female

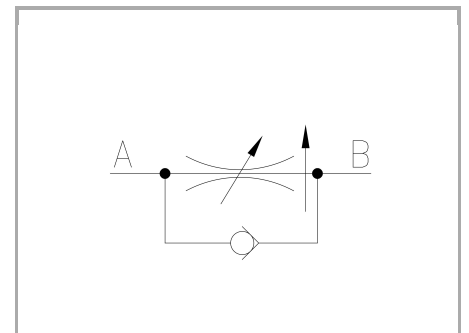

Technical information

Technical description

The double acting flow control valves, pressure compensated and including high capacity single acting valve to allow the free flow in one direction. They include two necks in series: • the first one with port section definable by an external control; • the second one with automatically variable section in relation with counter pressure variations on use. The choice of the adjustable neck situated upstream is which best ensures the precision of the valve towards variations of the fluid temperature. Regarding the structure of the valve, the following points must be underlined: • the rigorous symmetry of the internal components such as to impede unforeseen perturbations of the static and dynamic balances; • the optimisation of the arrangement of internal spring controlling the intervention of the automatic throttling, with variable preload with throttling fixed setting, useful to improve the behaviour at medium-high flow rates; • the geometry of the passage across which the flow is automatically throttled, designed to minimize the effect of the flow hydromechanics forces on the total balance of the moving element; • the accuracy of the machining which enabled to cancel any hysteresis effect of mechanical origin; • the original aesthetic feature, underlined by the particular form of the control knob; • the easiness to reset the flow value thanks to reference pointers. Moreover we believe important to underline the choice of the constructive solution fitting to the concept of "double valence" of the components, according to which the central body, configured as a threaded cartridge and insertable in the two different bodies at the base or directly in standard modular units, brings about the three marketed versions: • FT 277/2 two-way • FT 277/ 5 two-way with single-acting valve • FT 287/2 with cartridge mounted. This solution enables the user to request the single modular components to be assembled according to the application $\pm 1\%$ of the flow rate.

Materials

CORPO BASE / BASE BODY	Acciaio/Steel 11 S Mn Pb 37-UNI EN 10087
CORPO CARTUCCIA / CARTRIDGE BODY	Acciaio/Steel 35 S Mn Pb 10-UNI EN 10087
GRUPPO DI COMPENSAZIONE / COMPENSATING UNIT	Acciaio/Steel 39 Ni Cr Mo 3-UNI EN 10083
GUARNIZIONI / GASKETS	Di serie NBR - A richiesta FPM/Standard NBR-on demand FPM
ANELLI ANTIESTRUSIONE / ANTIEXTRUSION RINGS	PTFE
MANOPOLA TIPO MA / KNOB TYPE MA	Alluminio/Aluminum GD AlSi12- UNI EN AB 46100



Technical data

TIPO / TYPE	PRESSIONE ESERCIZIO BAR / WORKING PRESSURE BAR	MIN. ΔP DI FUNZIONAMENTO BAR / MIN. WORKING ΔP BAR	TEMPERATURA ESERCIZIO / WORKING TEMPERATURE	GRADO DI FILTRAZIONE μm / FILTRATION GRADE μm
14	320	7,5	-20°C/+70°C	25
38	320	10	-20°C/+70°C	25
12	320	12	-20°C/+70°C	25
34	320	15	-20°C/+70°C	25

Dimensional tables and drawings

TIPO / TYPE	A UNI 338	B	C	D	E	ØF	G	H	L	CH	PESO / WEIGHT KG
14	1/4" G	12,5	93,5	107	28	33	17	M30x1,5	4,5	45	1,400
38	3/8" G	12,5	112,5	129,5	32	38	27	M35x1,5	6	50	2,000
12	1/2" G	15,5	136	150	38	47	28,5	M40x1,5	6,5	60	3,500
34	3/4" G	17	163	182,5	45	58	35	M50x1,5	7,5	70	7,000

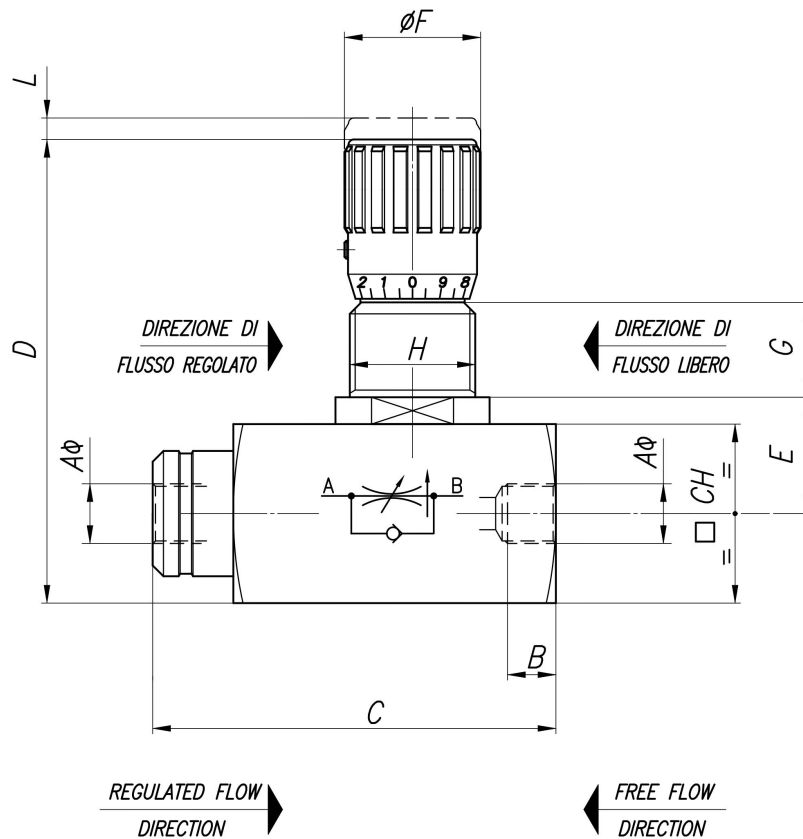



Flow rate curves

