



## METRIC Threads cartridge double-acting flow control valves

### FT 267/2

Double-acting flow control valves available from 1/8" to 1" size - METRIC THREADS  
Max.working pressure 320 Bar, adjustable oil flow rate from 0,2 to 200 Lt./min. (depending on the size)

**Double-acting control**

**No pressure compensated flow control**

**METRIC threads**

**Carbon steel**

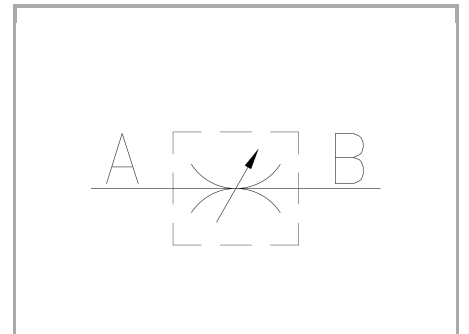

## Technical information

### Technical description

They allow for regulation of flow in both directions.

### Materials

CORPO / BODY	Acciaio/Steel 11 S Mn Pb 37-UNI EN 10087
SPILO DI REGOLAZIONE / ADJUSTING NEEDLE	Acciaio legato/Alloy Steel
GUARNIZIONI / GASKETS	Di serie NBR - A richiesta FPM/Standard NBR-on demand FPM
ANELLI ANTIESTRUSIONE / ANTIEXTRUSION RINGS	PTFE
MANOPOLA TIPO MA - RA / KNOB TYPE MA - RA	Alluminio/Aluminum GD AlSi12- UNI EN AB 46100
MANOPOLA TIPO MP / KNOB TYPE MP	ABS



## Technical data

TIPO / TYPE	PRESSIONE ESERCIZIO BAR / WORKING PRESSURE BAR	MIN. PRESSIONE SCOPPIO BAR / MIN. BURSTING PRESSURE BAR	TEMPERATURA ESERCIZIO / WORKING TEMPERATURE	GRADO DI FILTRAZIONE $\mu\text{m}$ / FILTRATION GRADE $\mu\text{m}$
18	320	1300	-20°C/+100°C	25
14	320	1300	-20°C/+100°C	25
38	320	1300	-20°C/+100°C	25
12	320	1300	-20°C/+100°C	25
34	320	1300	-20°C/+100°C	25
100	320	1300	-20°C/+100°C	25

## Dimensional tables and drawings

TIPO / TYPE	$\varnothing A$ UNI 4534	$\varnothing B$	C	D	E	$\varnothing F$	$\varnothing F1$	G	H	L	CH	PESO / WEIGHT KG
18	M15x1	12	9,3	11,2	20,5	22	40	35	55,5	5	22	0,064
14	M20x1,5	14	11	15,5	26,5	27	50	42,5	68,5	7	27	0,125
38	M20x1,5	16	13	17,5	30,5	33	70	48,5	78,5	9	27	0,180
12	M27x2	19	15,5	24,5	40	38	80	56	96	10,5	32	0,305
34	M33x2	27	18	26	44	47	100	63,5	109	13	41	0,580
100	M42x2	35	22	30,5	52,5	58	120	82	134,5	20	50	1,185

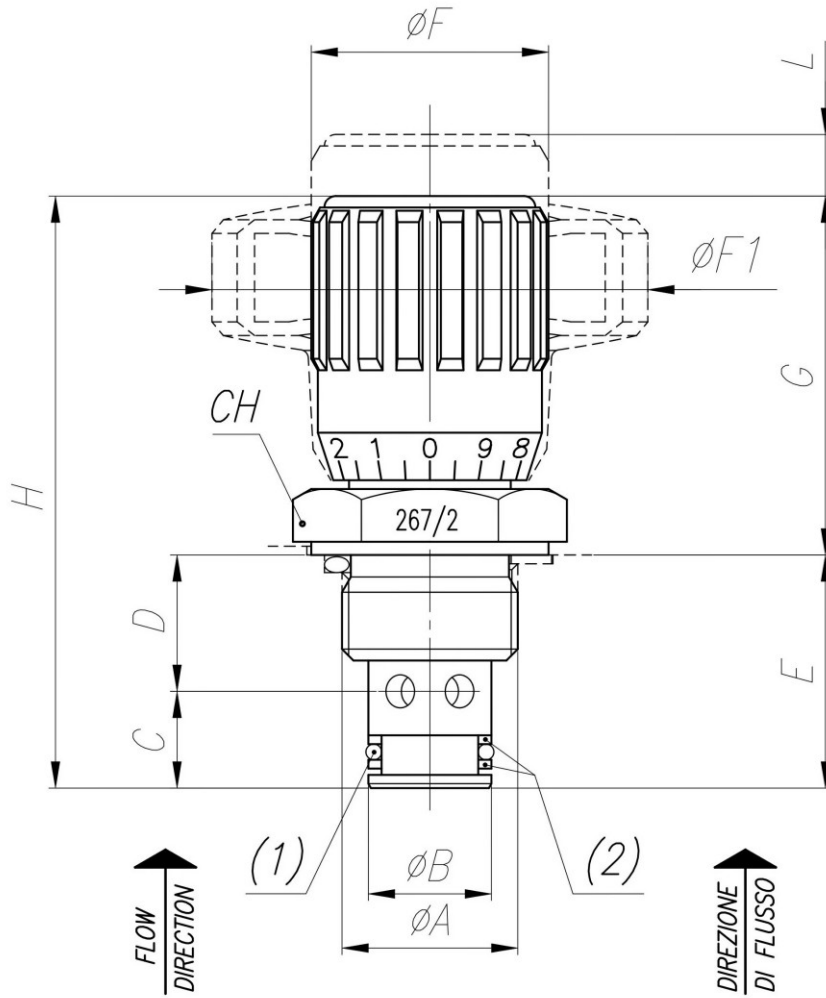

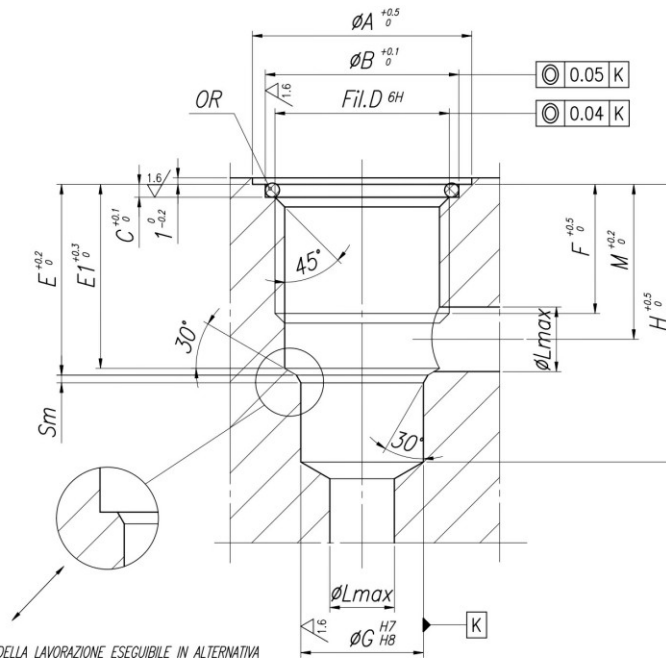

-PARTICOLARE DELLA LAVORAZIONE ESEGUIBILE IN ALTERNATIVA  
A QUELLA CONICA ELIMINANDO LA QUOTA E1

-DETAIL OF THE MACHINING THAT CAN BE CARRIED OUT AS AN  
ALTERNATIVE TO THE CONICAL ONE ELIMINATING THE DIMENSION E1

TENUTA REALIZZATA CON GUARNIZIONI OR SU SEDE PIANA  
SEALING DONE WITH OR GASKETS ON FLAT SEATING

	φA	φB	C	D UNI 45.34	E	E1	F	φG	H	φL	M	Sm	OR
18	23	19	2	M15x1	14	13	11	12	21.5	4	11.5	0.5	3056
14	28	24	2	M20x1.5	17.5	16.5	13.5	14	28.5	5	14.5	1	3075
38	28	24	2	M20x1.5	21	20.5	13.5	16	33.5	8	16.2	1.2	3075
12	34	30	2	M27x2	30	28.5	20	19	43	10	24	1.2	3100
34	43	36	2	M33x2	32.5	32	20	27	47.5	13	25	1.2	3125
100	60	45	2	M42x2	38.5	37	23.5	35	57	16	30.5	1.5	3162



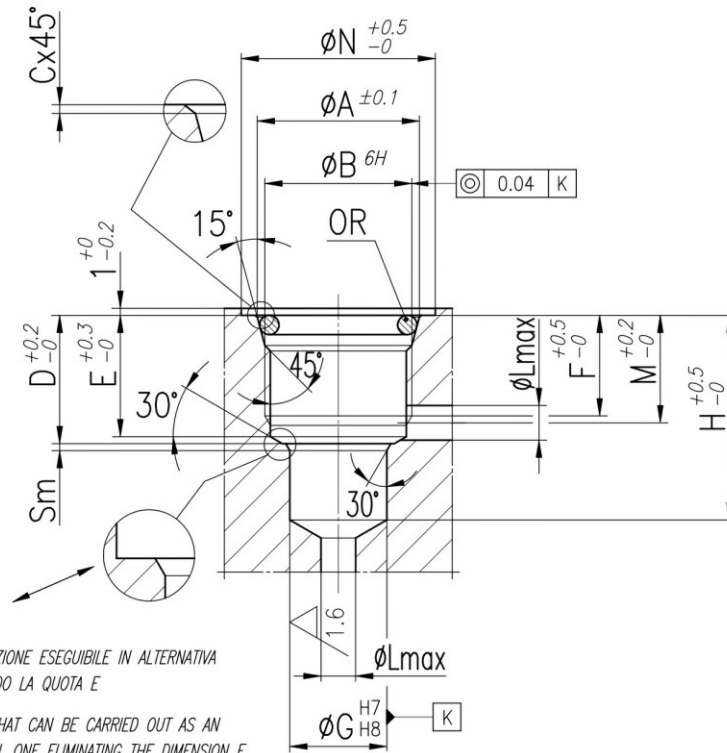

-PARTICOLARE DELLA LAVORAZIONE ESEGUIBILE IN ALTERNATIVA  
A QUELLA CONICA ELIMINANDO LA QUOTA E

-DETAIL OF THE MACHINING THAT CAN BE CARRIED OUT AS AN  
ALTERNATIVE TO THE CONICAL ONE ELIMINATING THE DIMENSION E

TENUTA REALIZZATA CON GUARNIZIONI OR SU SEDE CONICA  
SEALING DONE WITH OR GASKETS ON CONICAL SEATING

	φA	φB <small>UNI 4534</small>	C	D	E	F	φG	H	φL	M	φN	Sm	OR
18	16.5	M15x1	0.25	14	13	11	12	21.5	4	11.5	23	0.5	2050
14	22.3	M20x1.5	0.25	17.5	16.5	13.5	14	28.5	5	14.5	28	1	3068
38	22.3	M20x1.5	0.25	21	20.5	13.5	16	33.5	8	16.2	28	1.2	3068
12	29.1	M27x2	0.3	30	28.5	20	19	43	10	24	34	1.2	132
34	36	M33x2	0.3	32.5	32	20	27	47.5	13	25	43	1.2	4112
100	45	M42x2	0.3	38.5	37	23.5	35	57	16	29	60	1.5	4150



## Flow rate curves

