



Pilot pressure reducing valves Cetop 3

FT 376/4

Pressure reducing stackable valves Cetop3, pilot control, available with controlled flow on A-B-P ports. Max. working pressure 320 Bar

Cetop 3 valves - NG6

Pressure reducing

Pilot control

Carbon steel

Setting regulation field:

05=10-60 Bar | 10=30-160 Bar | 20=60-260 Bar

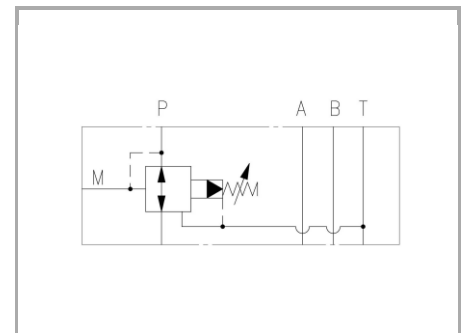

Technical information

Technical description

These valves are CETOP 03 reducing pressure in plate modular execution, ISO 4401 for superimposable mountings. Their function is to protect the secondary circuit from over pressure as they allow an inverted flow rate from the use to discharge T.

Materials

CORPO VALVOLA / BODY VALVE	Acciaio/Steel 11 S Mn Pb 37-UNI EN 10087
CORPO CARTUCCIA / CARTRIDGE BODY	Acciaio/Steel 11 S Mn Pb 37-UNI EN 10087
SPILO DI REGOLAZIONE / ADJUSTING NEEDLE	Acciaio legato/Alloy Steel
GUARNIZIONI / GASKETS	Di serie NBR - A richiesta FPM/Standard NBR-on demand FPM
ANELLI ANTIESTRUSIONE / ANTIEXTRUSION RINGS	PTFE
MANOPOLA TIPO MA / KNOB TYPE MA	Alluminio/Aluminum GD AISi12- UNI EN AB 46100



Technical data

CAMPO REGOLAZIONE TARATURA SETTING REGULATION FIELD	
FT 376/4-03	05 = 10-60 Bar
	10 = 30-160 Bar
	20 = 60-260 Bar

TIPO / TYPE	PRESSIONE ESERCIZIO BAR / WORKING PRESSURE BAR	TEMPERATURA ESERCIZIO / WORKING TEMPERATURE	CLASSE DI CONTAMINAZIONE FLUIDO / FLUID CONTAMINATION CLASS
A	320	-20°C/+80°C	ISO 4406 19/17/14
B	320	-20°C/+80°C	ISO 4406 19/17/14
P	320	-20°C/+80°C	ISO 4406 19/17/14



Dimensional tables and drawings

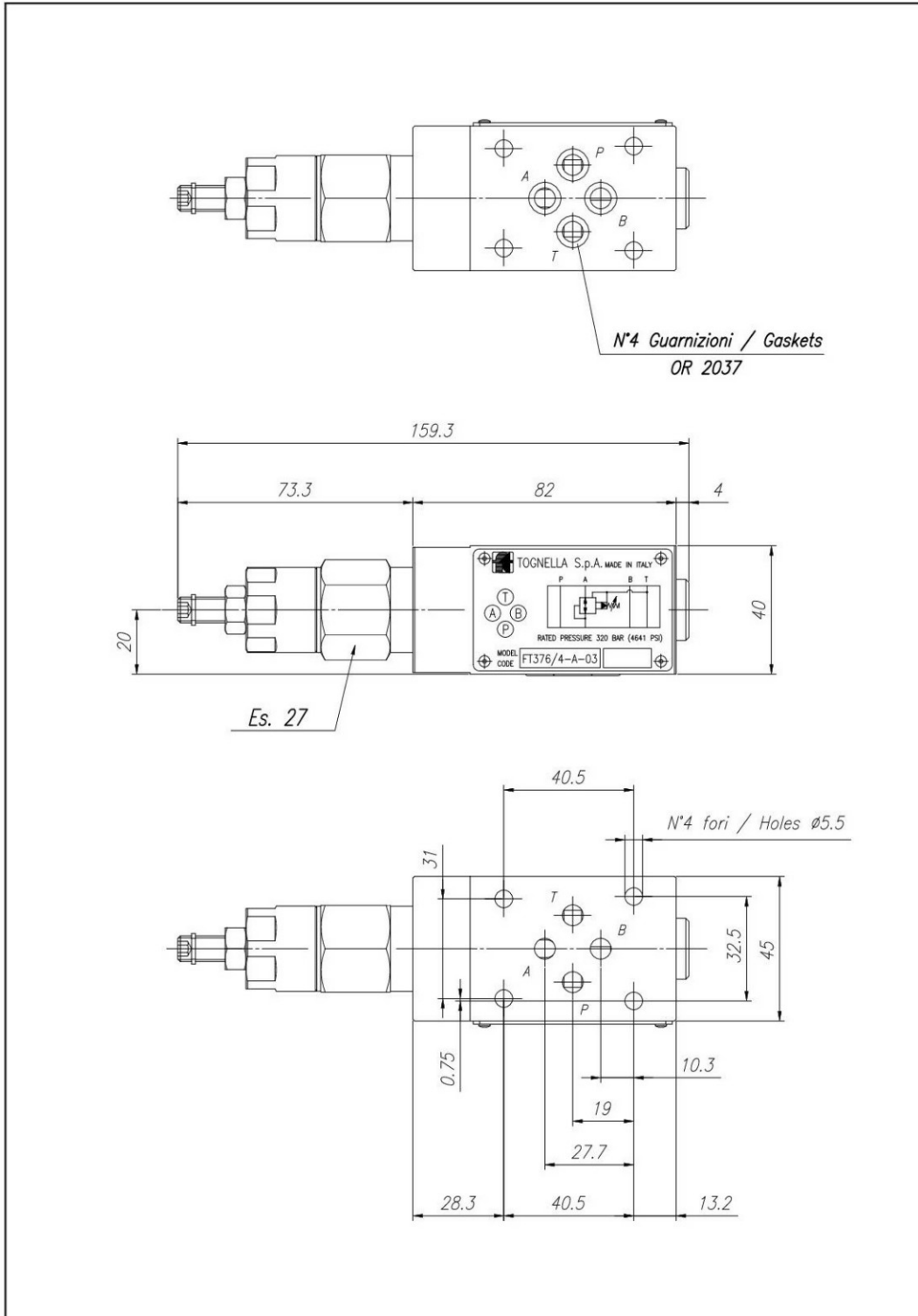

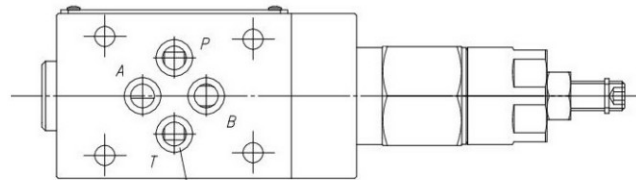

N°4 Guarnizioni / Gaskets
OR 2037

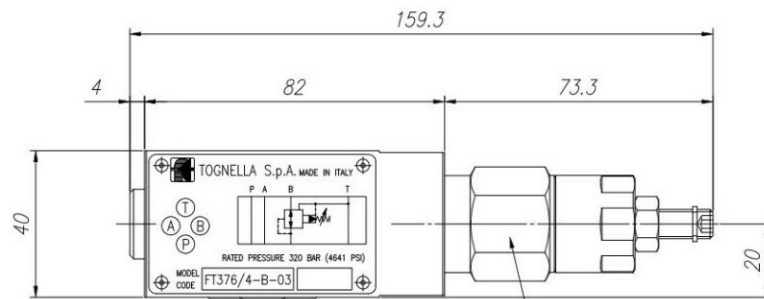

Es. 27

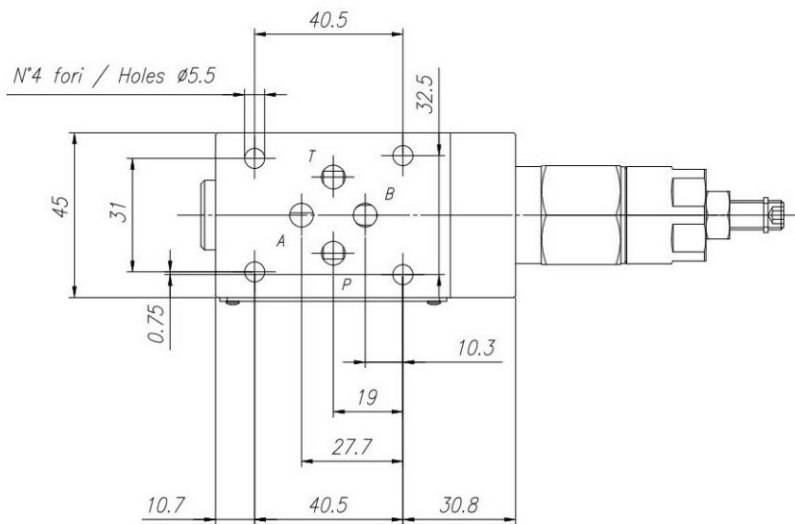

N°4 fori / Holes $\varnothing 5.5$

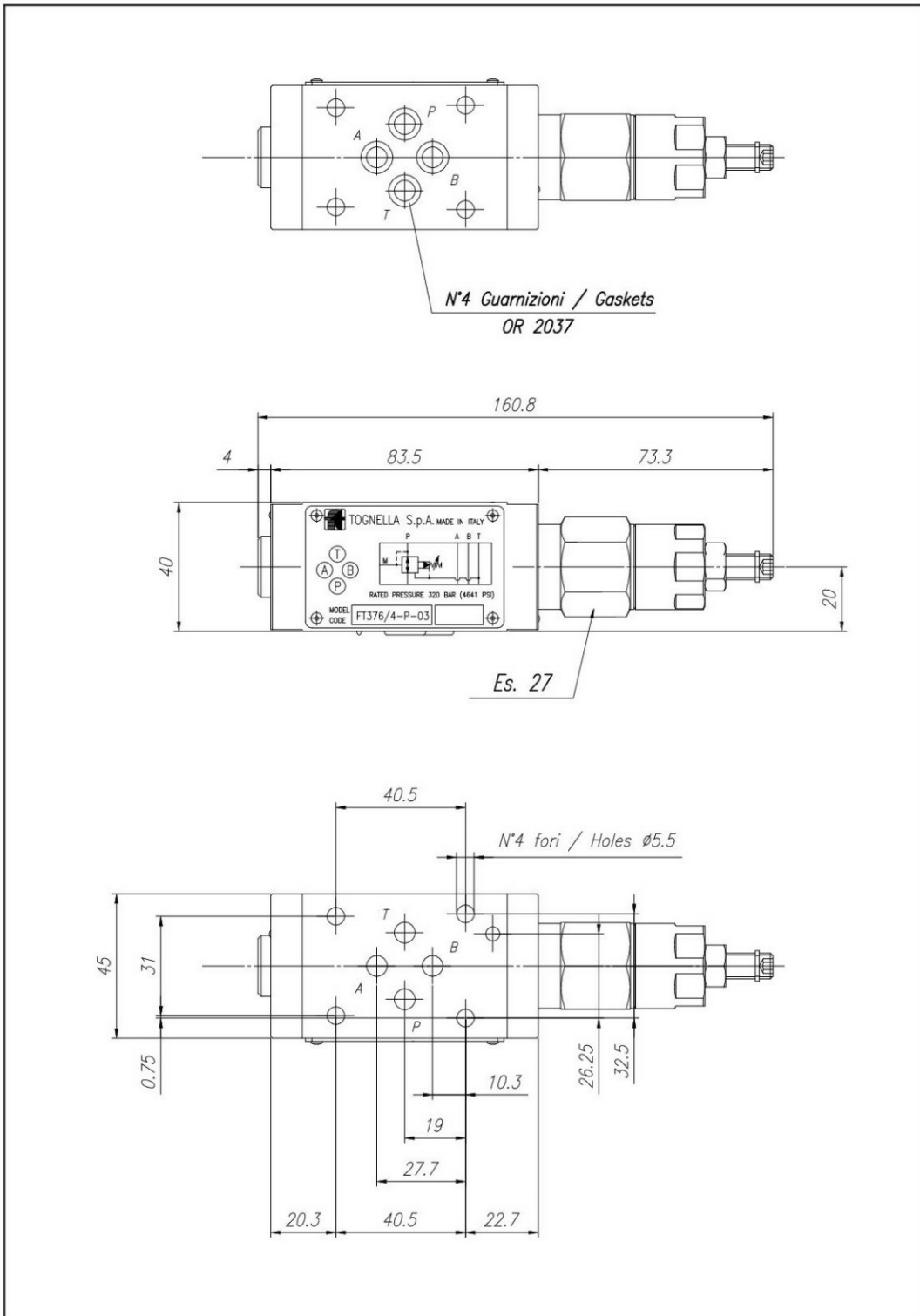



Flow rate curves

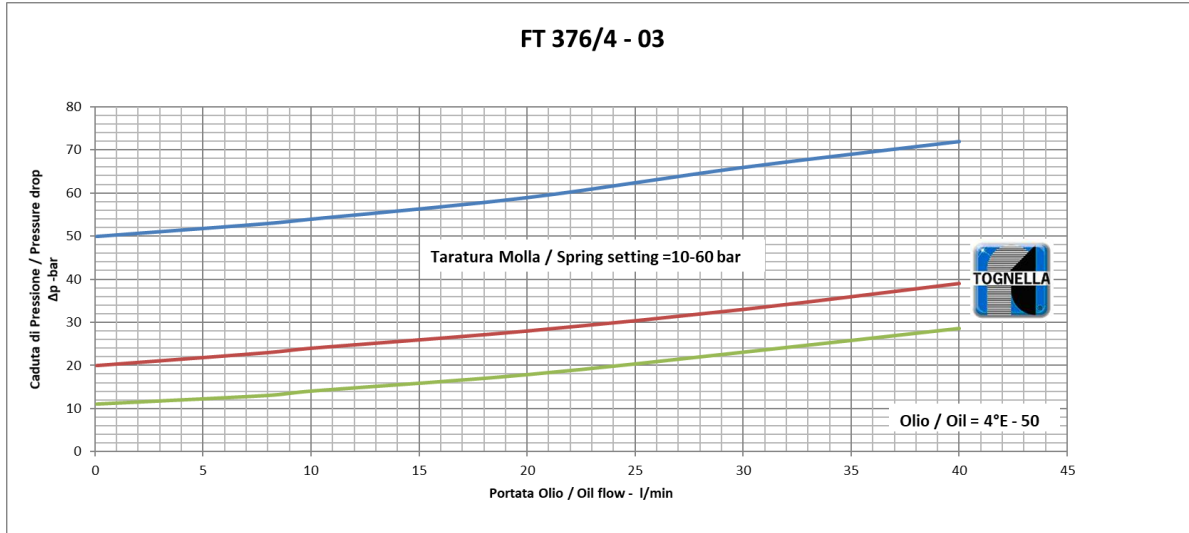

Q1

