



Valvole di regolazione bidirezionale a cartuccia FILETTATURE METRICHE

FT 2267/2

Regolatori di flusso bidirezionali disponibili da 1/8" a 1" - FILETTI METRICI Pressione Massima 320 Bar, Portate di olio regolate da 0,2 a 200 L/min. (a seconda della misura)

Regolazione bidirezionale

Regolazione non compensata

Filetti METRICI

Acciaio Inox Aisi 316

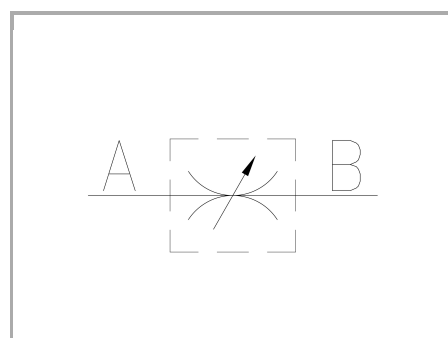

Informazioni tecniche

Descrizione tecnica

Regolano il flusso in entrambi i sensi. Sono costituite da un corpo cartuccia filettato METRICO, idoneo per montaggio in blocchi integrati, e uno spillo di regolazione opportunamente configurato in modo da ottenere : • efficace tenuta metallica • linearità di flusso in apertura • regolazione accurata nel campo della portata caratteristica. Conservano l'apprezzato sistema del doppio riferimento (volantino + fascetta serigrafati) per una facile identificazione della portata regolata.

Materiali

CORPO VALVOLA / VALVE BODY	Acciaio INOX / Stainless Steel AISI 316
SPILO DI REGOLAZIONE / ADJUSTING NEEDLE	Acciaio INOX / Stainless Steel AISI 630
GUARNIZIONI / GASKETS	FPM
ANELLI ANTIESTRUSIONE / ANTIEXTRUSION RINGS	PTFE
MANOPOLA TIPO MA - RA / KNOB TYPE MA - RA	Alluminio/Aluminum GD AISi12- UNI EN AB 46100
MANOPOLA TIPO MP / KNOB TYPE MP	ABS



Dati tecnici

TIPO / TYPE	PRESSIONE ESERCIZIO BAR / WORKING PRESSURE BAR	MIN. PRESSIONE SCOPPIO BAR / MIN. BURSTING PRESSURE BAR	TEMPERATURA ESERCIZIO / WORKING TEMPERATURE	GRADO DI FILTRAZIONE μm / FILTRATION GRADE μm
18	320	1300	-20°C/+130°C	25
14	320	1300	-20°C/+130°C	25
38	320	1300	-20°C/+130°C	25
12	320	1300	-20°C/+130°C	25
34	320	1300	-20°C/+130°C	25
100	320	1300	-20°C/+130°C	25
112	320	1300	-20°C/+130°C	25

Tablelle dimensionali e disegno quotato

TIPO / TYPE	ϕA UNI 4534	ϕB	C	D	E	ϕF	$\phi F1$	G	H	L	CH	PESO / WEIGHT KG
18	M15x1	12	9,3	11,2	20,5	22	40	35	55,5	5	22	0,064
14	M20x1,5	14	11	15,5	26,5	27	50	42,5	68,5	7	27	0,125
38	M20x1,5	16	13	17,5	30,5	33	70	48,5	78,5	9	27	0,180
12	M27x2	19	15,5	24,5	40	38	80	56	96	10,5	32	0,305
34	M33x2	27	18	26	44	47	100	63,5	109	13	41	0,580
100	M42x2	35	22	30,5	52,5	58	120	82	134,5	20	50	1,185
112	M52x2	45	31,5	33	64,5	58	120	85	148	25	60	1,600

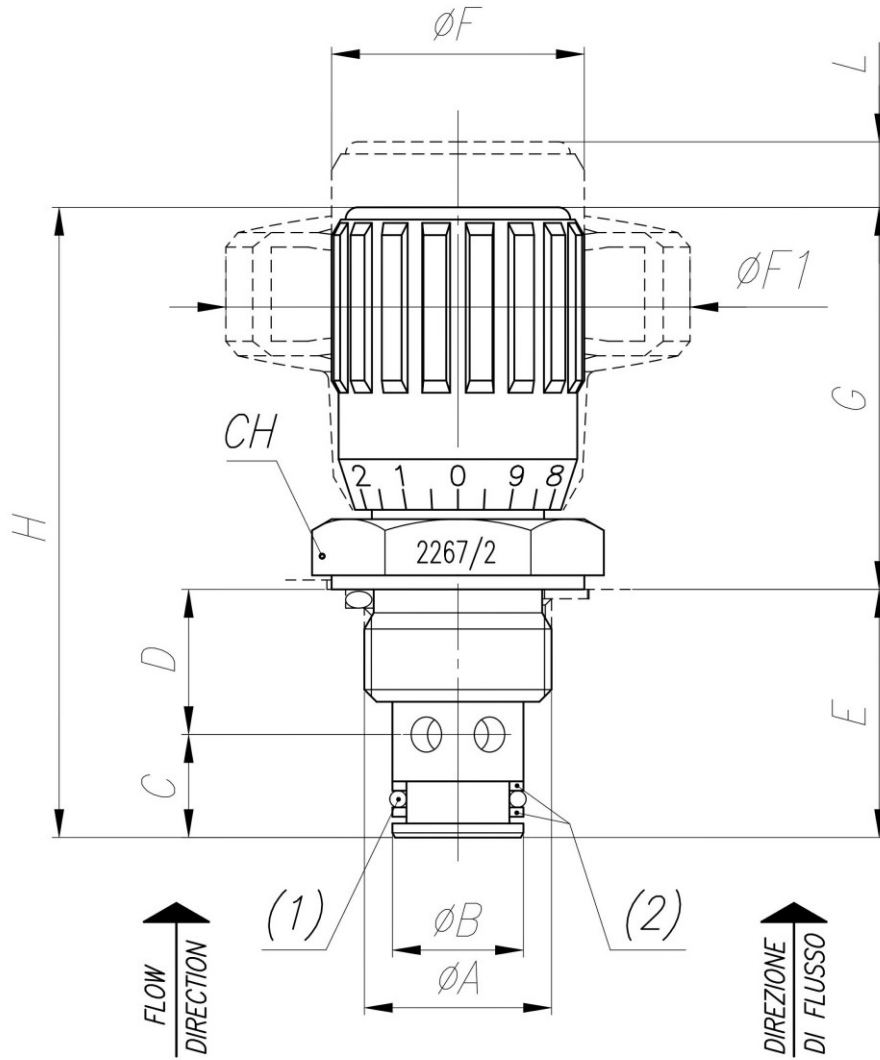

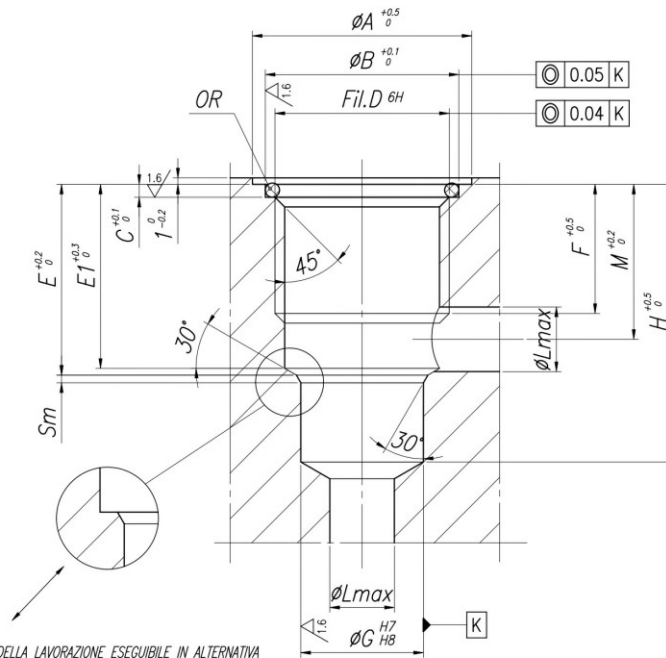

-PARTICOLARE DELLA LAVORAZIONE ESEGUIBILE IN ALTERNATIVA A QUELLA CONICA ELIMINANDO LA QUOTA E1
 -DETAIL OF THE MACHINING THAT CAN BE CARRIED OUT AS AN ALTERNATIVE TO THE CONICAL ONE ELIMINATING THE DIMENSION E1

TENUTA REALIZZATA CON GUARNIZIONI OR SU SEDE PIANA
 SEALING DONE WITH OR GASKETS ON FLAT SEATING

	φA	φB	C	D UNI 45.34	E	E1	F	φG	H	φL	M	Sm	OR
18	23	19	2	M15x1	14	13	11	12	21.5	4	11.5	0.5	3056
14	28	24	2	M20x1.5	17.5	16.5	13.5	14	28.5	5	14.5	1	3075
38	28	24	2	M20x1.5	21	20.5	13.5	16	33.5	8	16.2	1.2	3075
12	34	30	2	M27x2	30	28.5	20	19	43	10	24	1.2	3100
34	43	36	2	M33x2	32.5	32	20	27	47.5	13	25	1.2	3125
100	60	45	2	M42x2	38.5	37	23.5	35	57	16	30.5	1.5	3162

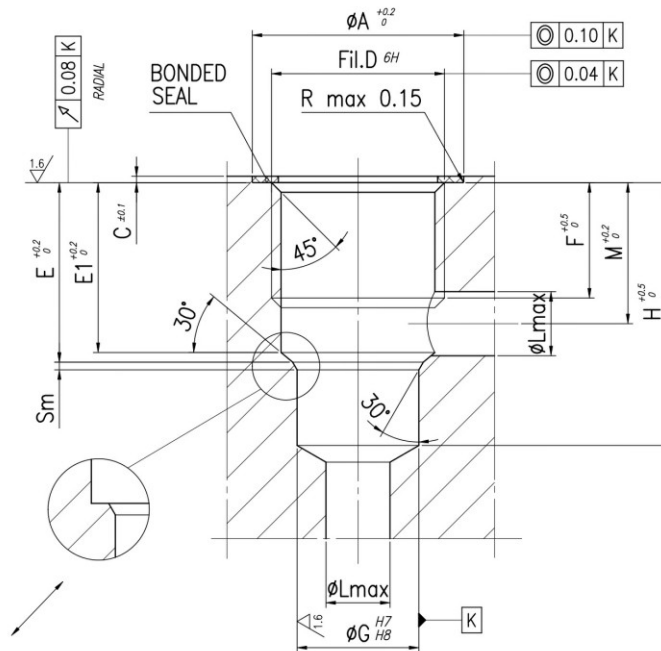

-PARTICOLARE DELLA LAVORAZIONE ESEGUIBILE IN ALTERNATIVA
A QUELLA CONICA ELIMINANDO LA QUOTA E1

-DETAIL OF THE MACHINING THAT CAN BE CARRIED OUT AS AN
ALTERNATIVE TO THE CONICAL ONE ELIMINATING THE DIMENSION E1

TENUTA REALIZZATA CON BONDED SEAL
SEALING DONE WITH BONDED SEALS

	ϕA	C	D <small>UNI 4534</small>	E	E1	F	ϕG	H	ϕL	M	Sm	BONDED SEAL
18	23	1	M15x1	13	12	9	12	20	4	10.3	0.5	400-512
14	27	1	M20x1.5	16.5	15.5	12	14	27	5	13.3	1	400-513
38	27	1	M20x1.5	20	19.5	12	16	32	8	15.2	1.2	400-513
12	33	1.3	M27x2	28	26.5	18	19	41	10	22	1.2	400-520
34	40	1.3	M33x2	30.5	30	18	27	45.5	13	23	1.2	400-515
100	50	1.3	M42x2	36.5	35	21.5	35	55	16	28.5	1.5	400-516

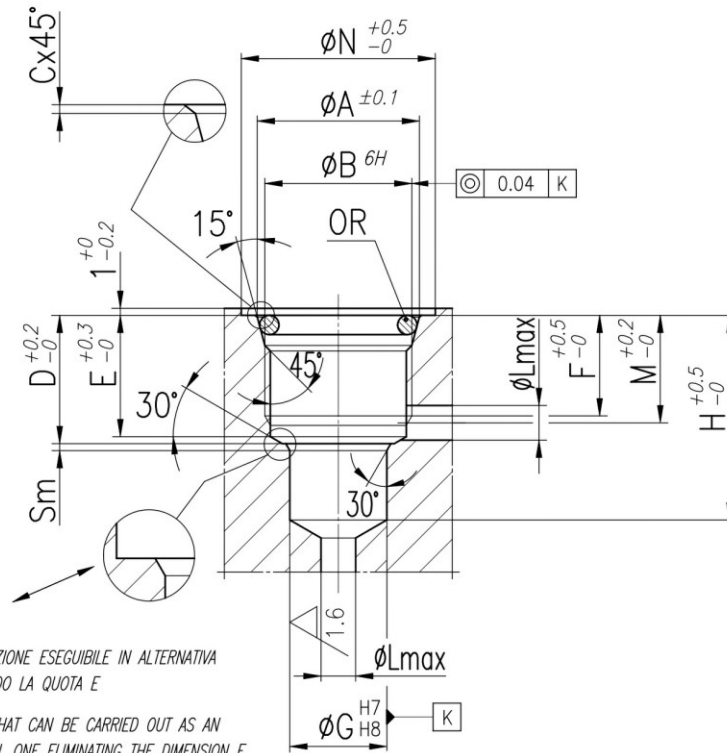

-PARTICOLARE DELLA LAVORAZIONE ESEGUIBILE IN ALTERNATIVA
A QUELLA CONICA ELIMINANDO LA QUOTA E

-DETAIL OF THE MACHINING THAT CAN BE CARRIED OUT AS AN
ALTERNATIVE TO THE CONICAL ONE ELIMINATING THE DIMENSION E

TENUTA REALIZZATA CON GUARNIZIONI OR SU SEDE CONICA
SEALING DONE WITH OR GASKETS ON CONICAL SEATING

	φA	φB <small>UNI 4534</small>	C	D	E	F	φG	H	φL	M	φN	Sm	OR
18	16.5	M15x1	0.25	14	13	11	12	21.5	4	11.5	23	0.5	2050
14	22.3	M20x1.5	0.25	17.5	16.5	13.5	14	28.5	5	14.5	28	1	3068
38	22.3	M20x1.5	0.25	21	20.5	13.5	16	33.5	8	16.2	28	1.2	3068
12	29.1	M27x2	0.3	30	28.5	20	19	43	10	24	34	1.2	132
34	36	M33x2	0.3	32.5	32	20	27	47.5	13	25	43	1.2	4112
100	45	M42x2	0.3	38.5	37	23.5	35	57	16	29	60	1.5	4150



Curve di portata

